

**Competition of Additive Manufacturing Technology -- Test Project for the A Module of Disassembly, Assembly and Debugging**

**Competition of Additive Manufacturing  
Technology -- Test Project for the A  
Module of Disassembly, Assembly and  
Debugging**

## Task I Equipment Assembly and Debugging (40 Points)

Teams should, in line with the assembly diagram provided onsite (see the attached drawing) and correct assembly processes, complete the mechanical assembly, device installation of the electrical control system, and circuit connection of a 3D printer, by using the 3D printing module kit (Equipment 1) provided onsite and reasonably selecting tools and measuring instruments. Then, the assembled 3D printer should be debugged and maintained to meet working and technical requirements. Additionally, designated parts should be 3D printed with such printer and used to replace the original parts of such printer.

### 1. Assembly of the mechanical system

Teams should use the materials of Equipment 1 (an FDM 3D printing equipment module kit) to complete the assembly of the mechanical system of the 3D printer in line with the “Assembly Diagram” and meet the technical requirements in the diagram.

### 2. Installation of the electrical system

Teams should use the materials of Equipment 1 (an FDM 3D printing equipment module kit) to complete the installation of the electrical system of the 3D printer in line with the “Wiring Schematic Diagram of the Mainboard of the 3D Printer”. Circuits should conform to process specifications and requirements. Wiring should avoid the heat dissipation area right above the circuit board.

### 3. Debugging of the whole machine

Upon the installation of the mechanical and electrical systems, the 3D printer should be debugged and maintained.

### 4. 3D printing test

Upon debugging and maintenance, competitors need to print the parts in Drawing-5 and Drawing-6. The printed pieces should not be in blue (which is the color of the original parts of the assembled 3D printer). Then, the printed pieces should be used to replace the original parts of the assembled 3D printer and meet the functional and technical requirements for parts.

### 5. Fill in record sheets on operation.

Marks and indicators are allocated below:

Indicators	Assembly process	Mechanical system	Electrical system	Debugging of the whole machine	Running test
Marks	5	19	6	5	5

Note: Competitors should fill in the record sheets truthfully and describe the working process (in a PowerPoint file in both Chinese and English. No points will be given if such file is completed only in Chinese.)

### Deliverables:

(1) Confirmation Form of the Equipment and Tools of the Disassembly, Assembly and Debugging Module.

(2) Record Sheet on the Assembly of the Disassembly, Assembly and Debugging Module.

(3) A set of digital models for the parts in Drawing-5 and Drawing-6 respectively. Each set contains a source document of models and an stp file. The two stp files are named "part-5" and "part-6" respectively.

(4) The 3D printed pieces of the part models in Drawing-5 and Drawing-6 are installed on the 3D printer to replace its original parts.

Table 1 List of Data to be Provided Regarding the A Module of Disassembly, Assembly and Debugging

No.	Model	Quantity	Model scale	Notes
1	Secondary lever 01	1	1:1	
2	Secondary lever 02	1	1:1	
3	Secondary lever 03	1	1:1	
4	Connecting rod	1	1:1	
5	Bridge connector	1	1:1	
6	Rotary block	1	1:1	
7	Claw	1	1:1	
Total		7		

**Note:** If the models allocated are not adequate, competitors should timely report to onsite judges. (After replenishing the models through the onsite technical support, onsite judges should sign the remark column.)

Drawing-1

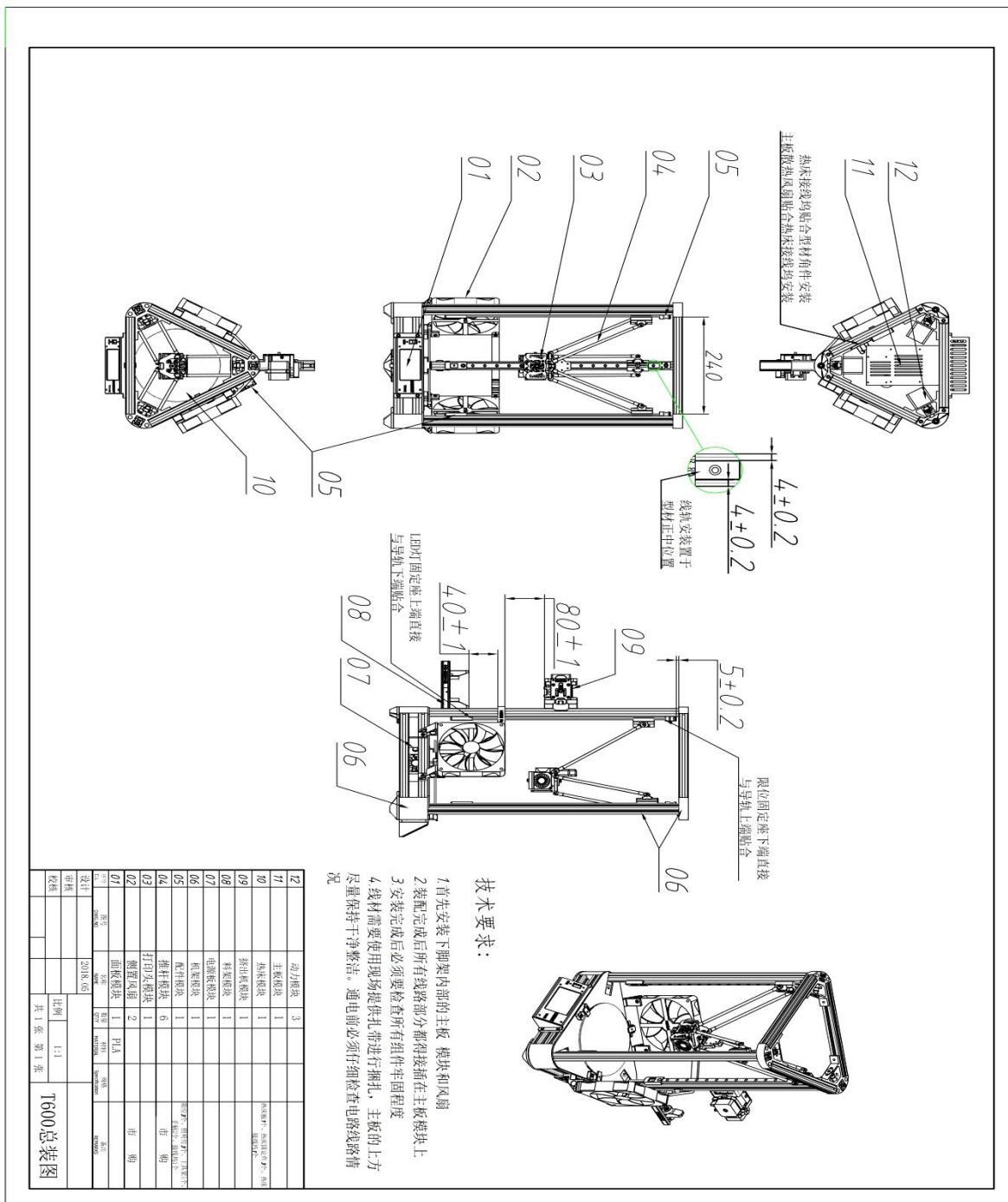

热床接线坞贴合型材角件安装  
主板散热风扇贴合热床接线坞安装

The docking station for the heat bed should be installed next to the corner fittings of profiles.  
The cooling fan of the mainboard should be installed next to the docking station for the heat bed.

线轨安装置于型材正中位置

The linear guide rail should be installed at the center of the profiles.

LED 灯固定座上端直接与导轨下端贴合	The upper part of the fixed base of the LED light should be directly connected to the lower part of the guide rail.
限位固定座下端直接与导轨上端贴合	The lower part of the fixed base of the stopper should be directly connected to the upper part of the guide rail.
技术要求： 1. 首先安装下脚架内部的主板、模块和风扇 2. 装配完成后所有线路部分都得接插在主板模块上 3. 安装完成后必须要检查所有组件牢固程度 4. 线材需要使用现场提供扎带进行捆扎，主板的上方尽量保持干净整洁。通电前必须仔细检查电路线路情况	Technical requirements: 1. First, the mainboard, modules, and fans inside the lower tripod should be installed. 2. Upon assembly, all circuits should be connected to the mainboard module. 3. Upon installation, the stability of all components must be checked. 4. Wires should be tied up with cable ties provided onsite. The place above the mainboard should be clean and tidy. Circuits must be carefully checked before energization.
动力模块	The power module
主板模块	The mainboard module
热床模块	The heat bed module
挤出机模块	The extruder module
料架模块	The feed rack module
电源板模块	The power board module
机架模块	The frame module
配件模块	The accessory module
推杆模块	The pusher module
打印头模块	The print head module
侧置风扇	The side-mounted fan
面板模块	The panel module
热床板 3 个、热床固定件 3 个、热床接线坞 1 个	Three heating plates, three fasteners for the heat bed, and one docking station for the heat bed
限位 3 个、照明灯 3 个、工具架 3 个、手柄 2 个、接线坞 1 个	Three limits, three lights, three tool racks, two handles, and one docking station
市购	Purchased
序号	No.
图号	Drawing No.
名称	Item
数量	Quantity
材料	Material
规格	Specification
备注	Notes
设计	Designed by
审核	Reviewed by
校验	Verified by
比例	Scale
共 1 张 第 1 张	Page 1 of 1

T600 总装图

T600 General assembly

Drawing-2

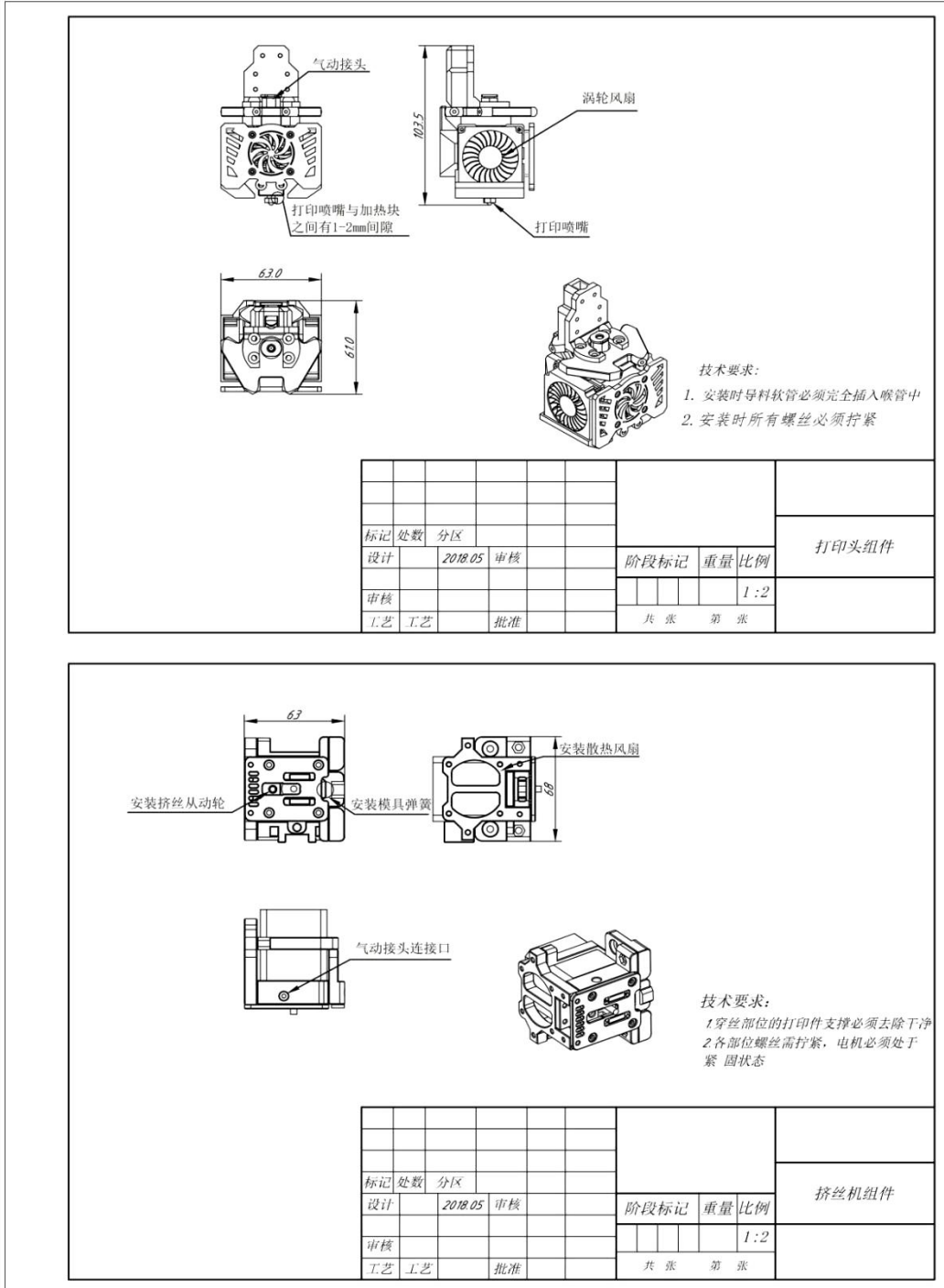

气动接头	Pneumatic connection
打印喷嘴与加热块之间有 1-2mm 间隙	The gap between the print nozzles and the

	heating block should be 1-2 mm
涡轮风扇	Turbofans
打印喷嘴	Print nozzles
技术要求: 1. 安装时导料软管必须完全插入喉管中 2. 安装时所有螺丝必须拧紧	Technical requirements: 1. During installation, the feed hose must be fully inserted into the venturi. 2. All screws must be fastened during installation.
标记	Mark
处数	Number
分区	Partition
设计	Designed by
审核	Reviewed by
工艺	Processes
2018.05	May 2018
审核	Reviewed by
批准	Approved by
阶段标记	Phase mark
重量	Weight
比例	Scale
共 张 第 张	Page of
打印头组件	The print head component
安装挤丝从动轮	Install the extruding driven wheel
安装模具弹簧	Install mold springs
安装散热风扇	Install cooling fans
气动接头接口	Interface of the pneumatic connection
技术要求: 1. 穿丝部位的打印件支撑必须去除干净 2. 各部位螺丝需拧紧,电机必须处于紧固状态	Technical requirements: 1. The support for the printed piece of wire threading must be completely removed. 2. The screws of all parts should be fastened. The motor must be fastened.
标记	Mark
处数	Number
分区	Partition
设计	Designed by
审核	Reviewed by
工艺	Processes
2018.05	May 2018
审核	Reviewed by
批准	Approved by
阶段标记	Phase mark
重量	Weight
比例	Scale
共 张 第 张	Page of
挤丝机组件	The extruder component



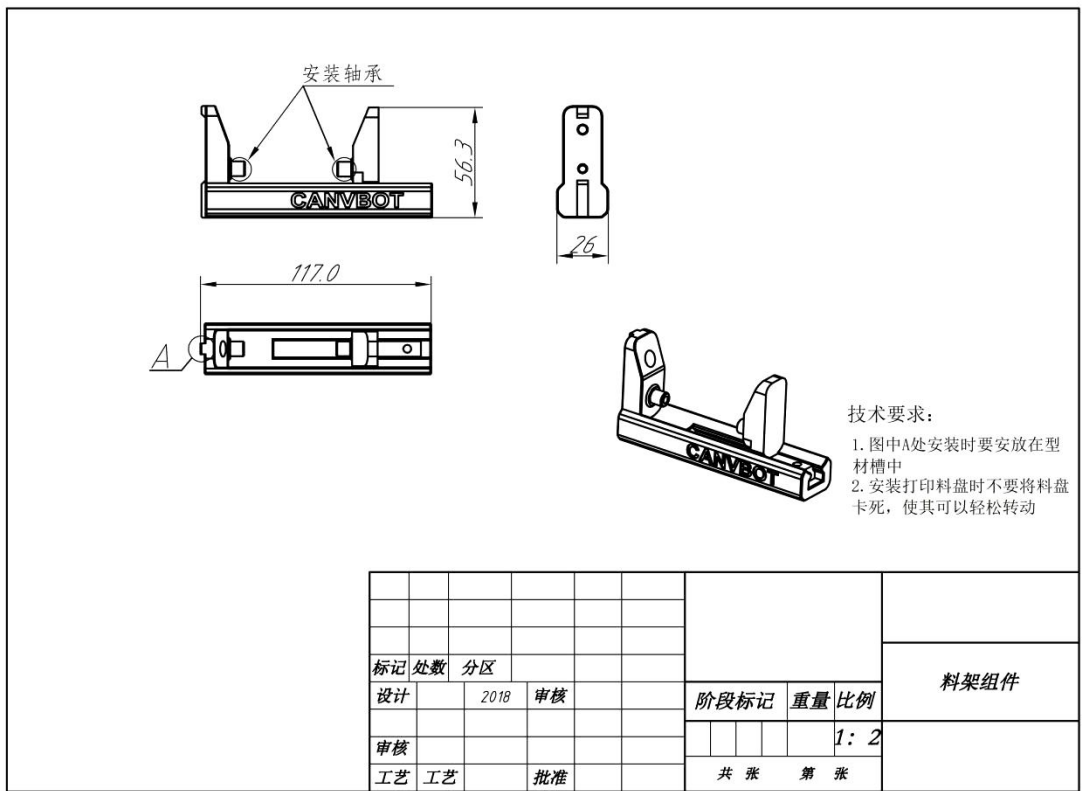
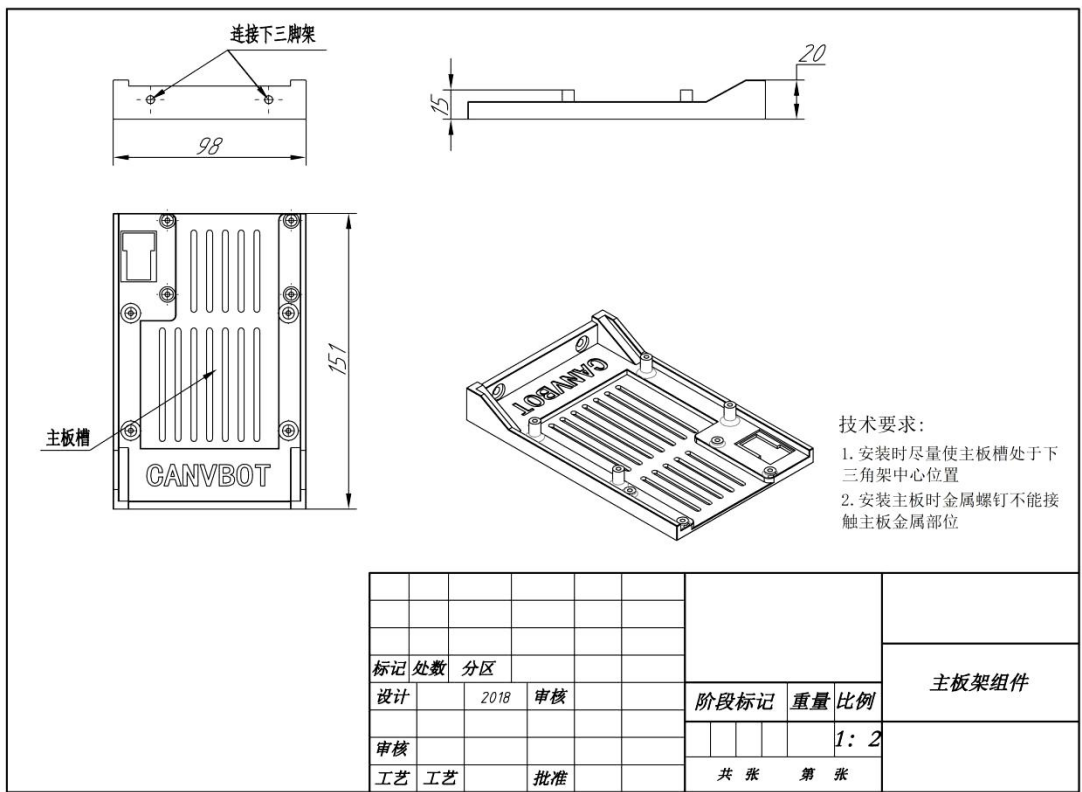

连接下三脚架	Connected to the lower tripod
主板槽	The mainboard slot
技术要求: 1. 安装时尽量使主板槽处于下三脚架中心位置 2. 安装主板时金属螺钉不能接触主板金属部位	Technical requirements: 1. The mainboard slot should be at the center of the lower tripod during installation. 2. Metal screws should not touch the metal part of the mainboard during installation.
标记	Mark
处数	Number
分区	Partition
设计	Designed by
审核	Reviewed by
工艺	Processes
2018	2018
审核	Reviewed by
批准	Approved by
阶段标记	Phase mark
重量	Weight
比例	Scale
共 张 第 张	Page of
主板架组件	The mainboard rack component
安装轴承	Installation of bearings
技术要求: 1. 图中 A 处安装时要安放在型材槽中 2. 安装打印料盘时不要将料盘卡死, 使其可以轻松转动	Technical requirements: 1. Point A in the drawing should be placed in the profile slot when installed. 2. Do not fasten the feeding tray when installing it. It should be turned easily.
标记	Mark
处数	Number
分区	Partition
设计	Designed by
审核	Reviewed by
工艺	Processes
2018	2018
审核	Reviewed by
批准	Approved by
阶段标记	Phase mark
重量	Weight
比例	Scale
共 张 第 张	Page of
料架组件	The feed rack component

Drawing-3

117.0

56.3

26

安装轴承

**技术要求:**

1. 图中A处安装时要安放在型材槽中
2. 安装打印料盘时不要将料盘卡死，使其可以轻松转动

		2018																		
设计	处数	分区	审核	批准																
审核	工艺																			
工艺																				
										阶段标记	重量	比例								
										共	张	第	张							
										1: 2			<b>料架组件</b>							

Drawing-4

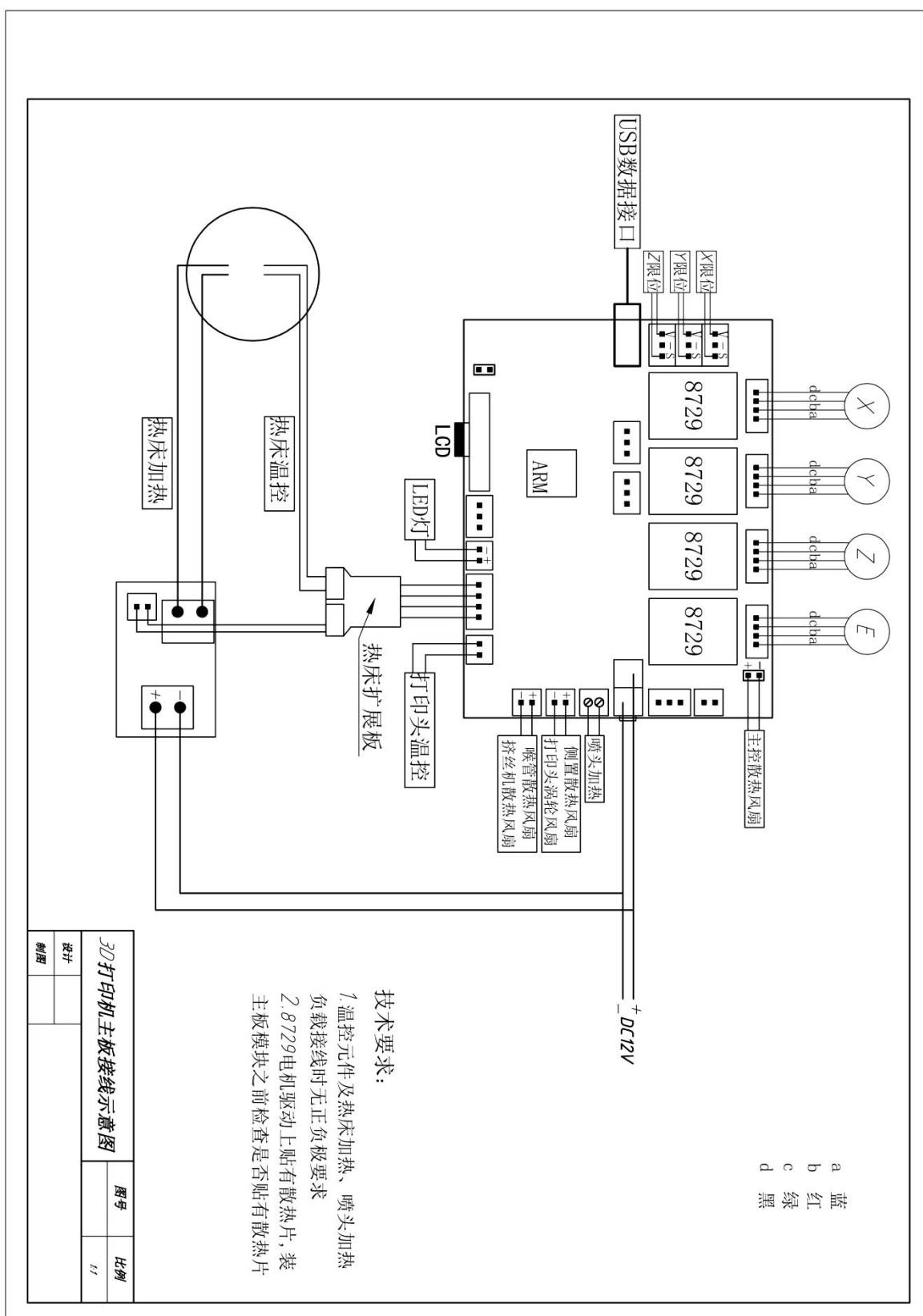

X 限位	The X limit
Y 限位	The Y limit
Z 限位	The Z limit
USB 数据接口	USB interface
主控散热风扇	The main cooling fan
喷头加热	Nozzle heating
侧置散热风扇	The side-mounted cooling fan
打印头涡轮风扇	The turbofan of the print head
喉管散热风扇	The cooling fan of the venturi
挤丝机散热风扇	The cooling fan of the extruder
打印头温控	Temperature control of the print head
热床扩展板	The expansion board of the heat bed
热床温控	Temperature control of the heat bed
热床加热	Heating of the heat bed
a 蓝 b 红 c 绿 d 黑	a Blue b Red c Green d Black
技术要求： 1. 温控元件及热床加热、喷头加热负载接线时无正负极要求 2. 8729 电机驱动上贴有散热片，装主板模块之前检查是否贴有散热片	Technical requirements: 1. There are no polarity requirements for the wiring for temperature control components and the heating of the heat bed and nozzles. 2. There should be a cooling fin on the 8729 motor drive. Check if there is a cooling fin, before installing the mainboard module.
3D 打印机主板接线示意图	Wiring Schematic Diagram of the Mainboard of the 3D Printer
图号	Drawing No.
比例	Proportion
设计	Designed by
制图	Drawn by

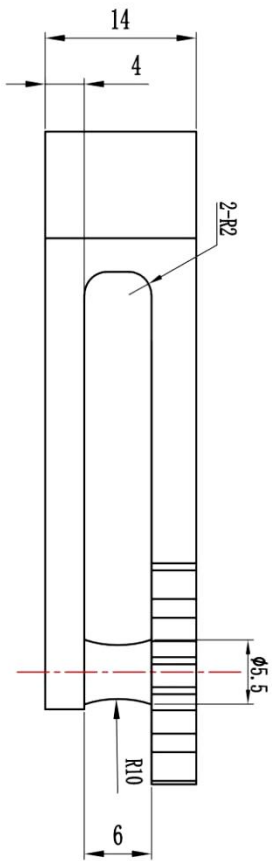
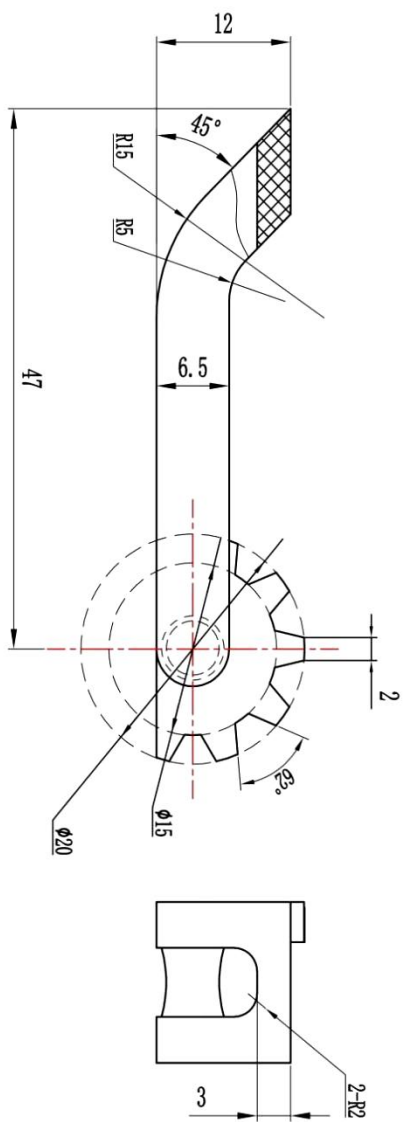

- 技术要求:**
1. 去毛边处理。
  2. 材料为PLA。
  3. 制造方式为3D打印。

设计	审核	工艺	标记	数量	更改	文件号	签字	日期

图样	标记	重量	比例
共	5	页	第
			1
			页

爪手 A

技术要求： 1. 去毛边处理。 2. 材料为 PLA。 3. 制造方式为 3D 打印。	Technical requirements:  1. Deburring. 2. The material should be PLA. 3. The manufacturing method should be 3D printing.
标记	Mark
处数	Number
更改文件号	Modified Document No.
签字	Signature
日期	Date
设计	Designed by
标准化	Standardization
审核	Reviewed by
工艺	Processes
日期	Date
图样标记	Mark of drawing
重量	Weight
比例	Proportion
共 5 页 第 1 页	Page 1 of 5
爪手 A	Claw A

Drawing-5

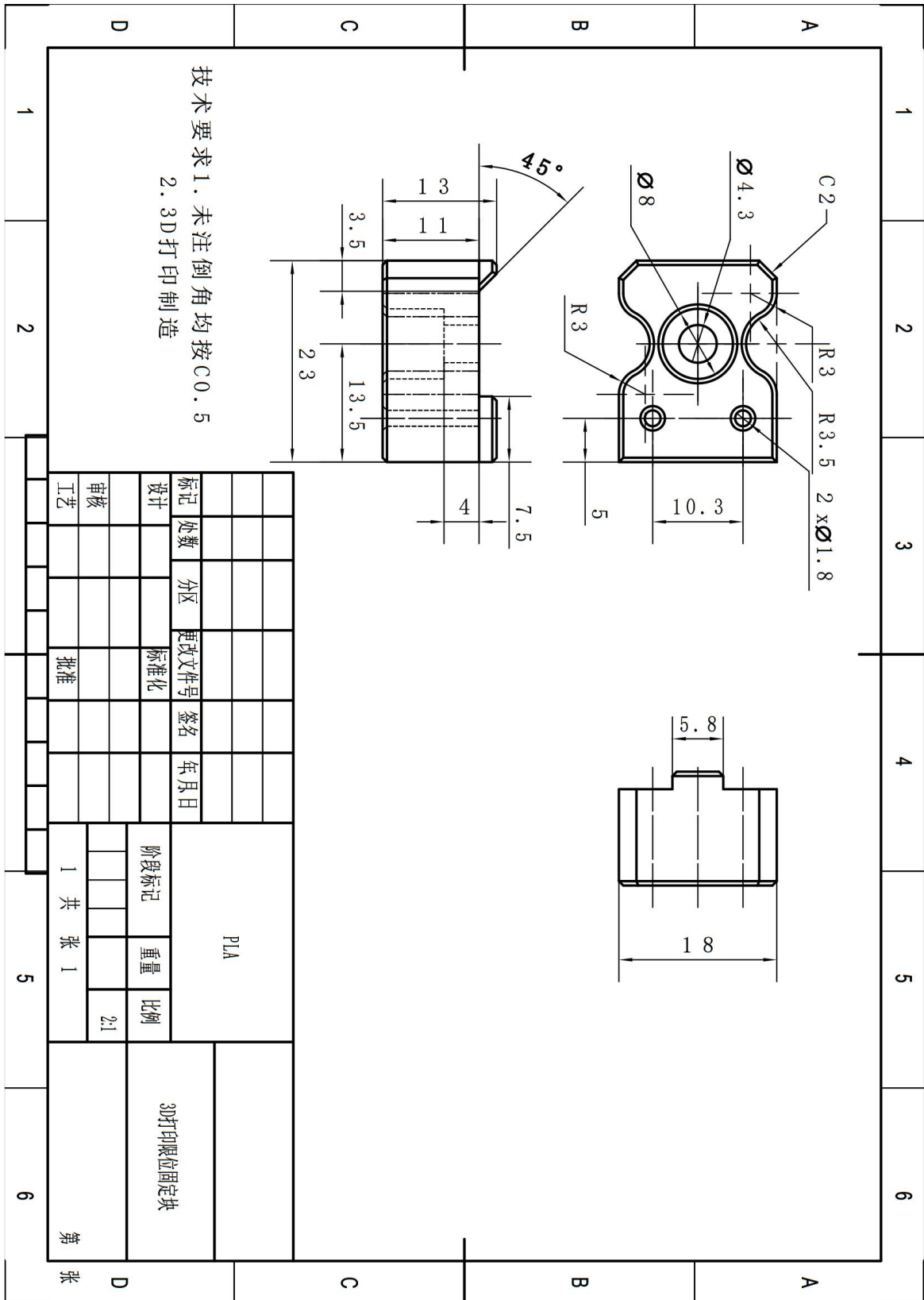



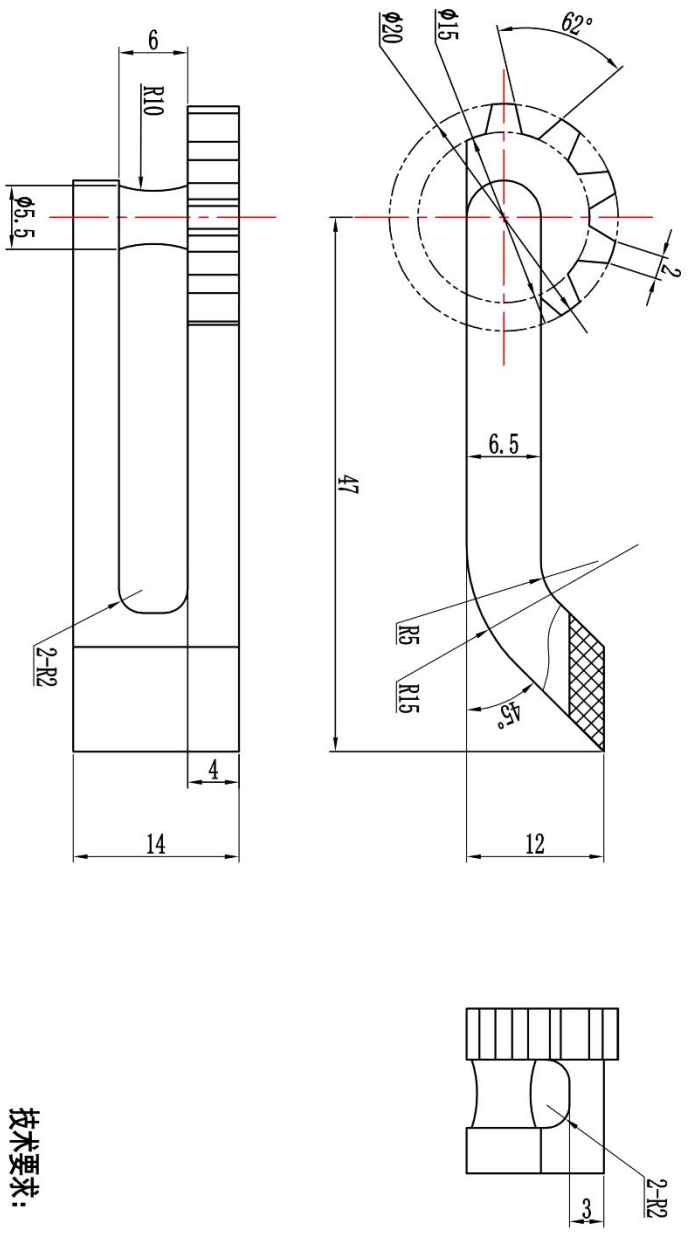

**技术要求:**  
 1. 去毛边处理。  
 2. 材料为PLA。  
 3. 制造方式为3D打印。

标记处数		更改文件号		签字		日期		图样标记		重量		比例		爪手 B
设计		标准化						共 5 页	第 2 页	2:1				
审核		日期												
工艺														

技术要求： 1. 去毛边处理。 2. 材料为 PLA。 3. 制造方式为 3D 打印。	Technical requirements: 1. Deburring. 2. The material should be PLA. 3. The manufacturing method should be 3D printing.
标记	Mark
处数	Number
更改文件号	Modified Document No.
签字	Signature
日期	Date
设计	Designed by
标准化	Standardization
审核	Reviewed by
工艺	Processes
日期	Date
图样标记	Mark of drawing
重量	Weight
比例	Proportion
共 5 页 第 2 页	Page 2 of 5
爪手 B	Claw B

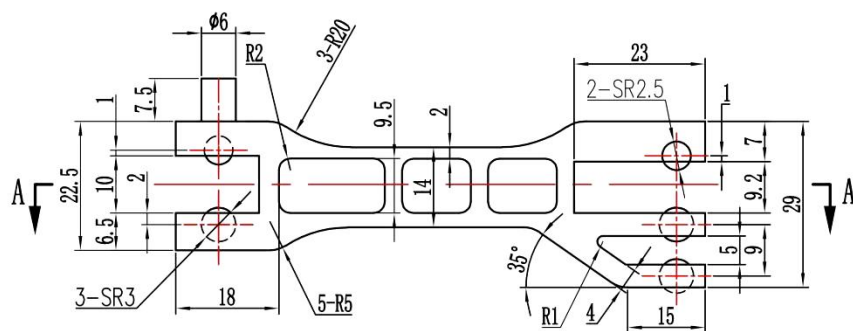

A-A

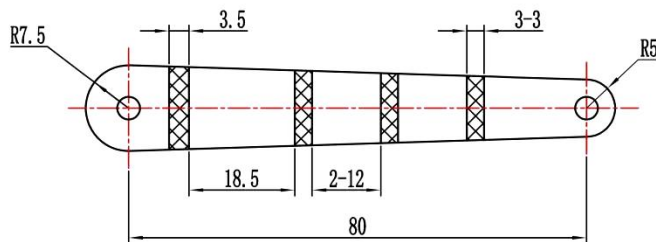

**技术要求:**

1. 去毛边处理。
2. 材料为PLA。
3. 制造方式为3D打印。

							主 臂
标记处数	更改文件号	签字	日期	图样标记	重量	比例	
设计		标准化				1:1	
审核							
工艺		日期		共 5 页	第 3 页		

技术要求： 1. 去毛边处理。 2. 材料为 PLA。 3. 制造方式为 3D 打印。	Technical requirements:  1. Deburring. 2. The material should be PLA. 3. The manufacturing method should be 3D printing.
标记	Mark
处数	Number
更改文件号	Modified Document No.
签字	Signature
日期	Date
设计	Designed by
标准化	Standardization
审核	Reviewed by
工艺	Processes
日期	Date
图样标记	Mark of drawing
重量	Weight
比例	Proportion
共 5 页 第 3 页	Page 3 of 5
主臂	The main arm

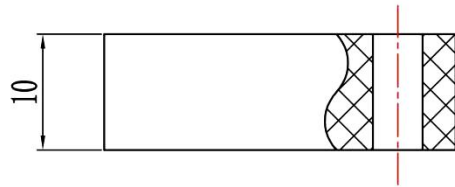
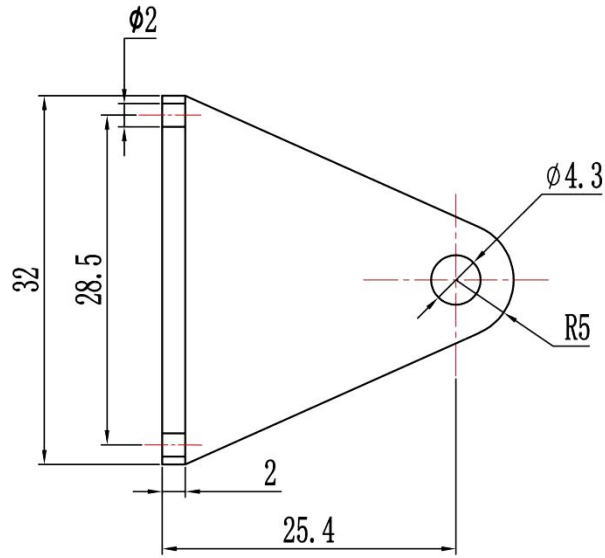

**技术要求:**

1. 去毛边处理。
2. 材料为PLA。
3. 制造方式为3D打印。

标记	处数	更改文件号	签字	日期						支撑架-设计参考
设计			标准化		图样标记	重量	比例			
审核							2:1			
工艺			日期		共 5 页	第 4 页				

技术要求： 1. 去毛边处理。 2. 材料为 PLA。 3. 制造方式为 3D 打印。	Technical requirements:  1. Deburring. 2. The material should be PLA. 3. The manufacturing method should be 3D printing.
标记	Mark
处数	Number
更改文件号	Modified Document No.
签字	Signature
日期	Date
设计	Designed by
标准化	Standardization
审核	Reviewed by
工艺	Processes
日期	Date
图样标记	Mark of drawing
重量	Weight
比例	Proportion
共 5 页 第 4 页	Page 4 of 5
支撑架-设计参考	Support rack—Design reference

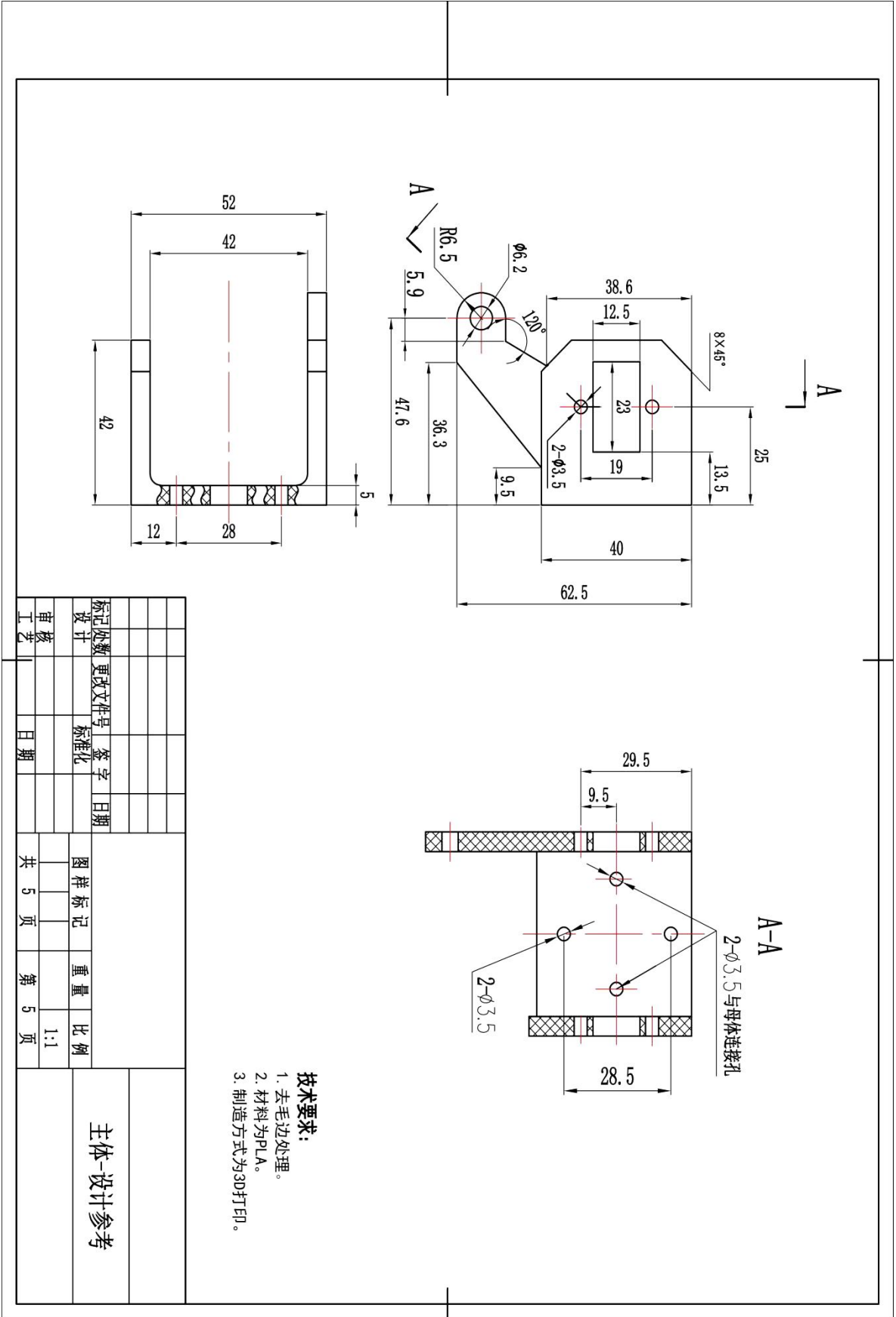

标记	次数	更改文件号	签字	日期	图样标记	重量	比例	主体-设计参考
设计		标准化						
审核					共 5 页	第 5 页	1:1	
工艺			日期					

与母体连接孔	Connecting hole to the matrix
技术要求： 1. 去毛边处理。 2. 材料为 PLA。 3. 制造方式为 3D 打印。	Technical requirements: 1. Deburring. 2. The material should be PLA. 3. The manufacturing method should be 3D printing.
标记	Mark
处数	Number
更改文件号	Modified Document No.
签字	Signature
日期	Date
设计	Designed by
标准化	Standardization
审核	Reviewed by
工艺	Processes
日期	Date
图样标记	Mark of drawing
重量	Weight
比例	Proportion
共 5 页 第 5 页	Page 5 of 5
主体-设计参考	The main body—Design reference



Drawing-6

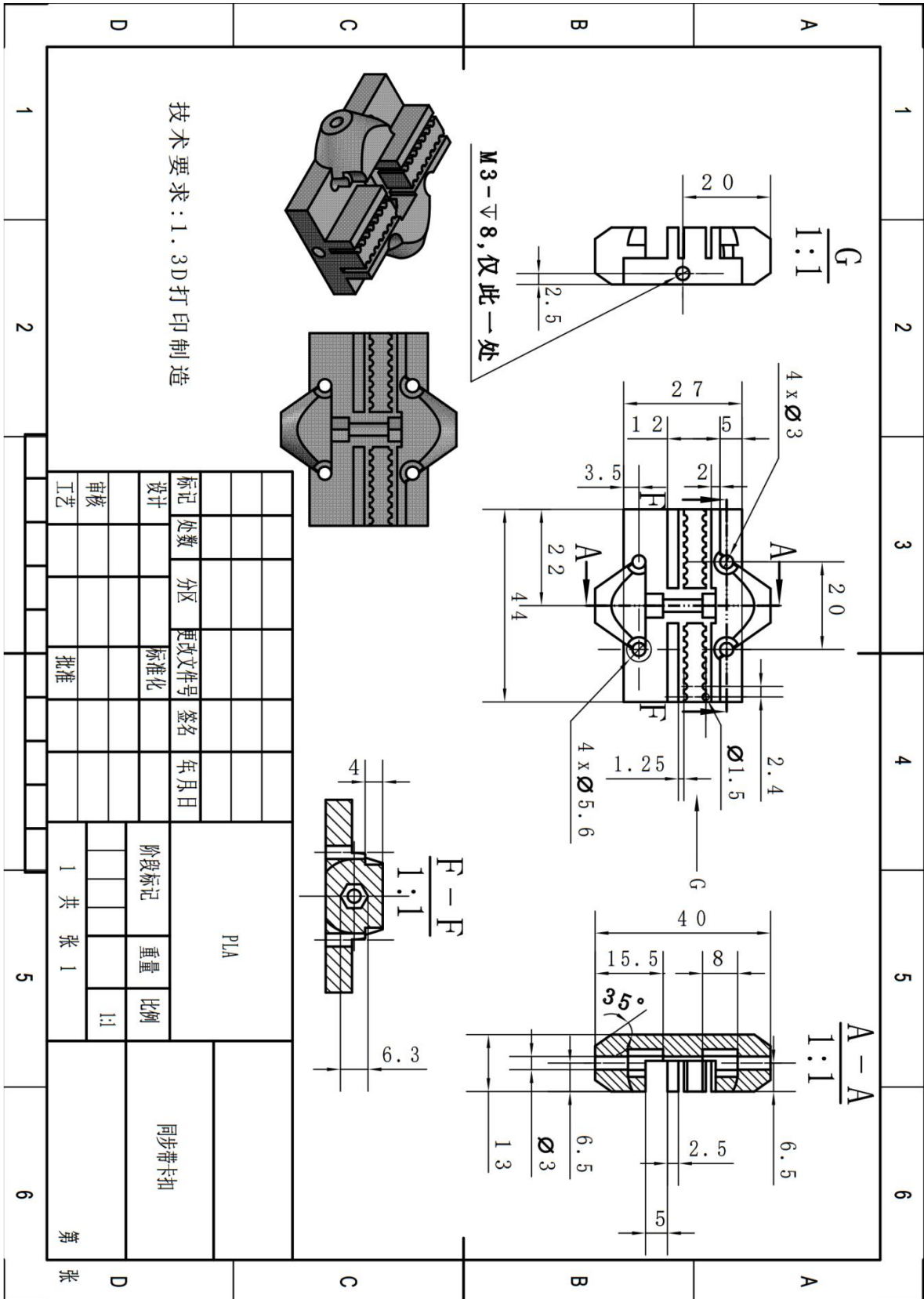

## Task II Assembly, Debugging and Maintenance of FDM 3D Printing Equipment (30 Points)

Faults has been set in advance. Competitors should fill in the record sheet of fault removal.

1. One 3D printer should be provided for the competition. “3D Printing Equipment 2” is for the purpose of troubleshooting and printing by competitors. Competitors must complete the assembly, debugging, fault removal, and testing of the printer and then use it for subsequent printing.
2. During the Competition, competitors should complete all operations in strict conformity with safety specifications and requirements. In case of special circumstances or equipment faults other than the pre-set ones, competitors should immediately report them to onsite staff and follow the instruction and arrangement of onsite judges.
3. Competitors must wear work clothes and insulated shoes in the workshop. Besides, female competitors must wear a helmet. Personal protection should be properly conducted to avoid accidents.

Indicators	Fault point 1	Fault point 2	Fault point 3	Fault point 4	Fault point 5	Fault point 6
Marks	5	5	5	5	5	5

Note: Competitors should fill in the record sheets truthfully and describe the whole working process (in a PowerPoint file in both Chinese and English. No points will be given if such file is completed only in Chinese.)

Deliverables:

One copy of Troubleshooting Record Sheet of the Disassembly, Assembly and Debugging Module.

## Task III Sample Printing (30 Points)

Modeling, printing, post-processing and assembly should be completed in line with the attached drawing of samples. The modeling and assembly of a set of samples should be completed by foreign competitors.

Indicators	PPT	Parts modeling	Assembly simulation	Switching of printing models	Slicing process	Sample effect
Marks	5	5	3	4	3	10

Marks and indicators are allocated below:

Note: Competitors should fill in the record sheets truthfully and describe the whole working process (in a PowerPoint file in both Chinese and English. No points will be given if such file is completed only in Chinese.)

**Attached drawings:**

1. The Assembly Diagram--one piece
2. The Parts Drawing--6 pieces (Including the 2D Engineering Drawings for Modeling and Design Reference)

3. In this part of the sample design, competitors abroad need to record the working process in advance or onsite foreign competitors should prepare an English PowerPoint file on the working process onsite.

**Deliverables:**

(1) One copy of the 3D Printing Processes Form of the Disassembly, Assembly and Debugging Module.

(2) A set of digital model files of the sample assembly model and an assembly of the printed pieces. The digital model files include a source document of models and an stp file, named "LubanKey".

(3) A PowerPoint file recording the working process from Tasks I to III.

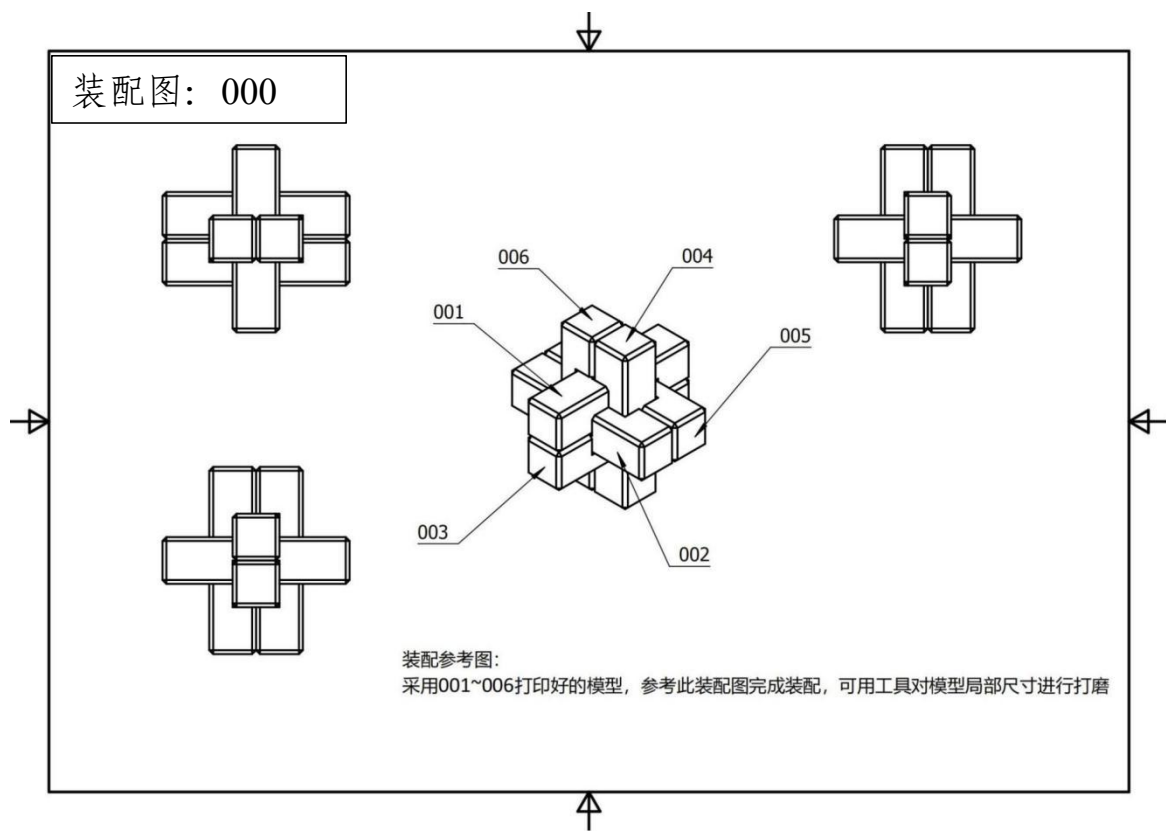

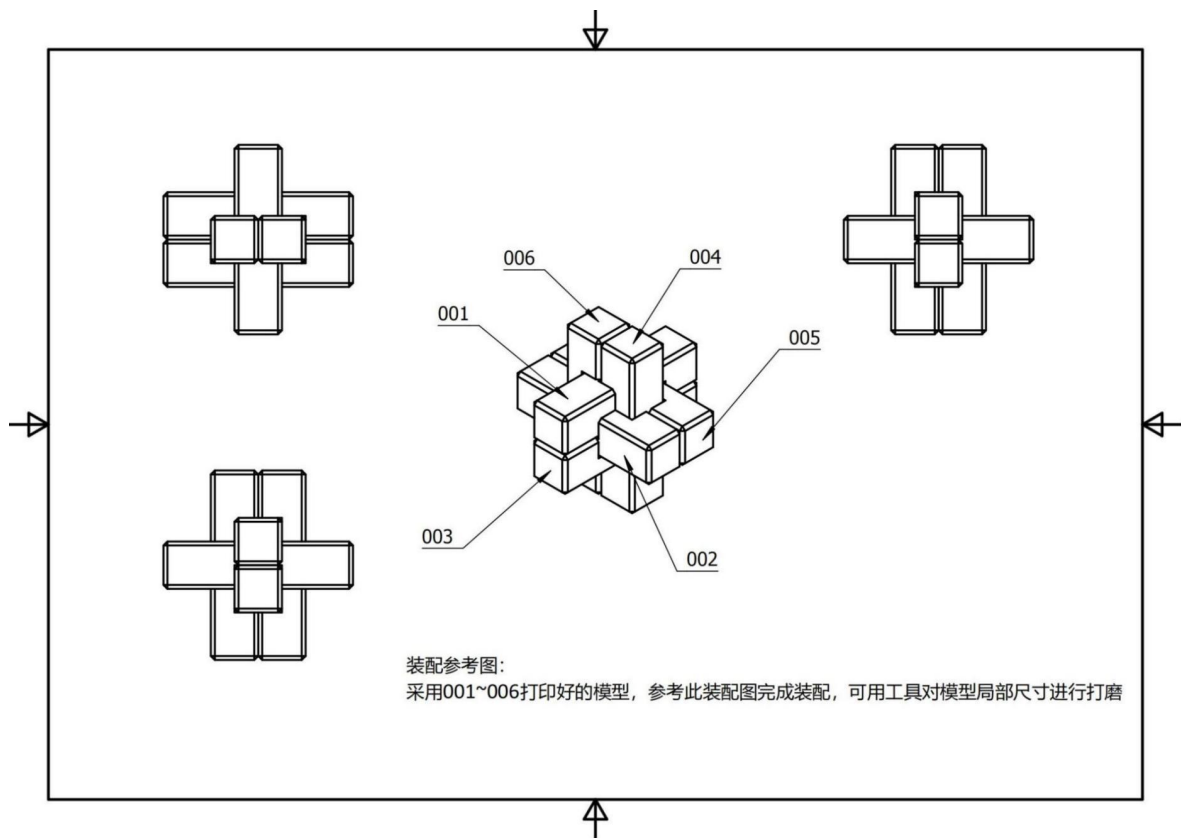

装配参考图	Reference Assembly Diagram
采用 001-006 打印好的模型，参考此装配图完成装配，可用工具对模型局部尺寸进行打磨	Use the printed model 001-006, complete assembly by referring to this assembly diagram, and polish the local dimensions of the model with tools if needed.

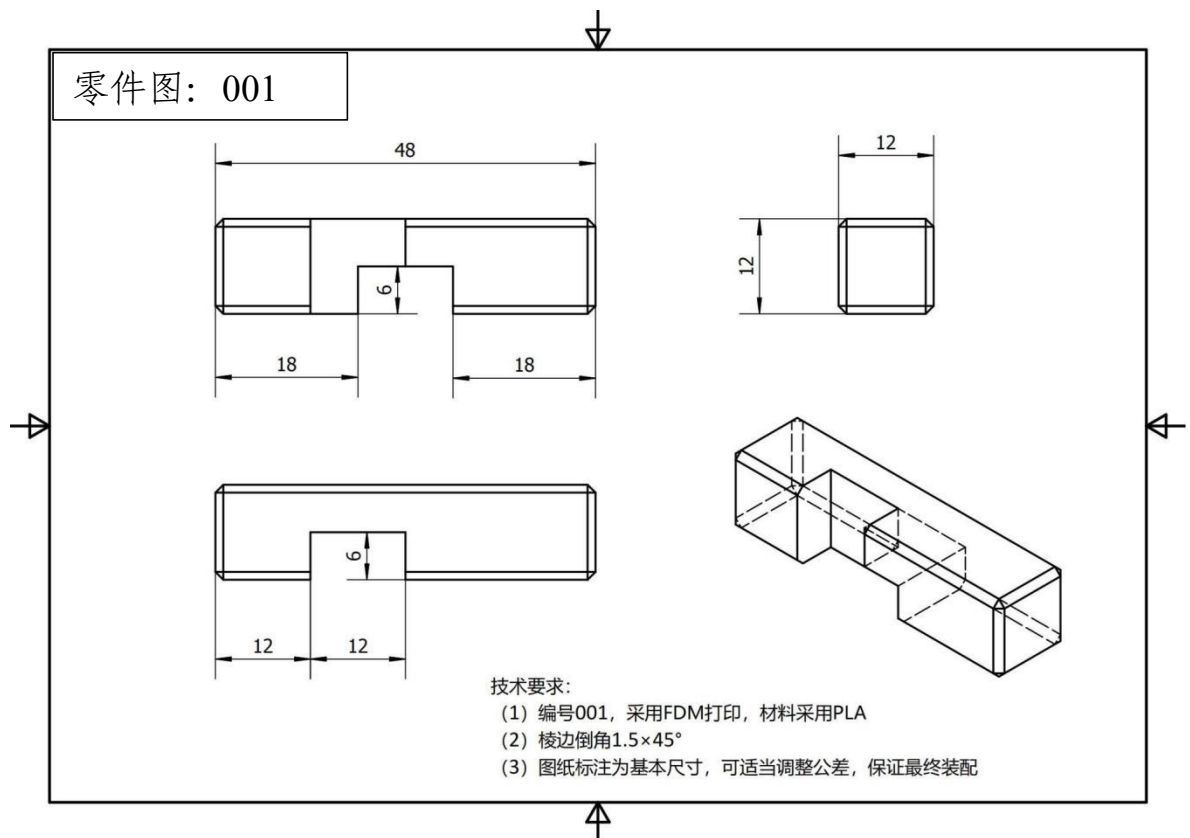

零件图 001	Parts Drawing 001
<p>技术要求:</p> <ol style="list-style-type: none"> <li>(1) 编号 001, 采用 FDM 打印, 材料采用 PLA</li> <li>(2) 棱边倒角 <math>1.5 \times 45^\circ</math></li> <li>(3) 图纸标注为基本尺寸, 可适当调整公差, 保证最终装配</li> </ol>	<p>Technical Requirements:</p> <ol style="list-style-type: none"> <li>(1) No. 001, use FDM print and PLA material</li> <li>(2) Seamed edge chamfer: <math>1.5 \times 45^\circ</math></li> <li>(3) The drawing is marked as basic size, tolerance can be adjusted to ensure final assembly</li> </ol>

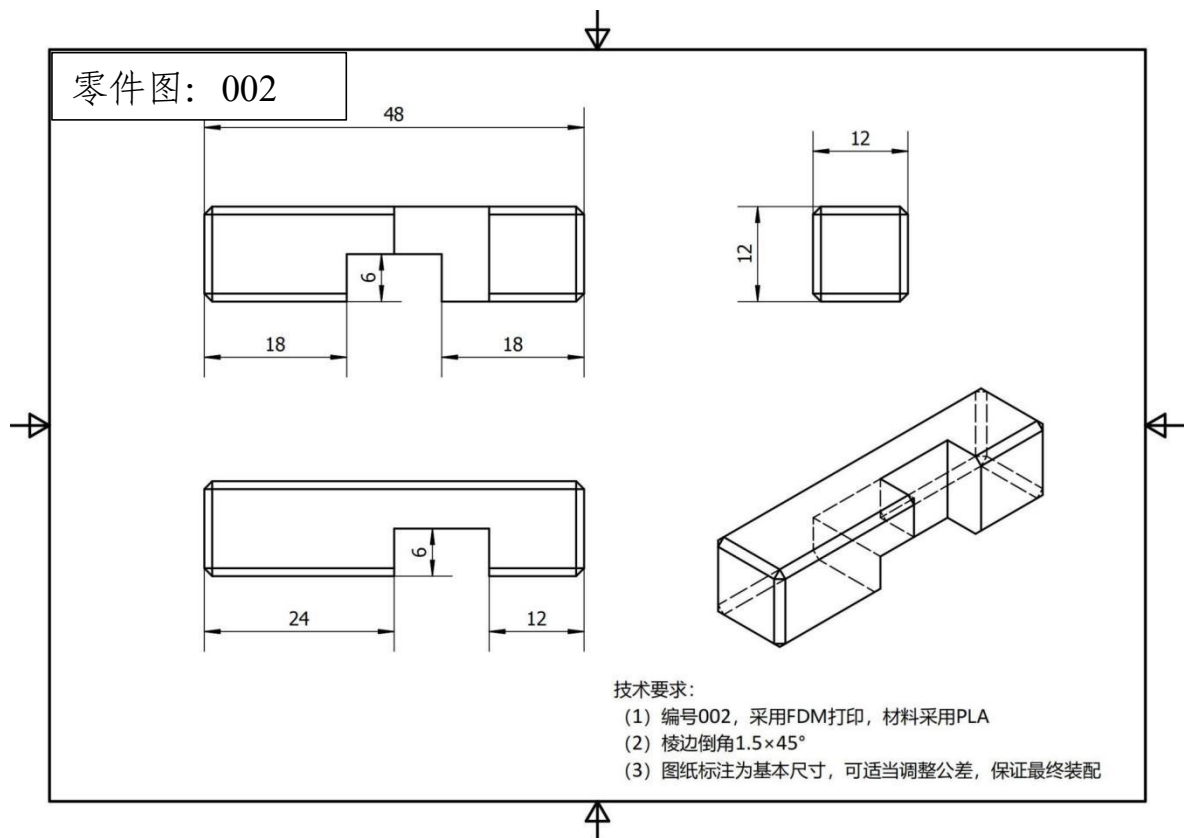

零件图 002	Parts Drawing 002
<p>技术要求:</p> <p>(1) 编号 002, 采用 FDM 打印, 材料采用 PLA</p> <p>(2) 棱边倒角 <math>1.5 \times 45^\circ</math></p> <p>(3) 图纸标注为基本尺寸, 可适当调整公差, 保证最终装配</p>	<p>Technical Requirements:</p> <p>(1) No. 002, use FDM print and PLA material</p> <p>(2) Seamed edge chamfer: <math>1.5 \times 45^\circ</math></p> <p>(3) The drawing is marked as basic size, tolerance can be adjusted to ensure final assembly</p>

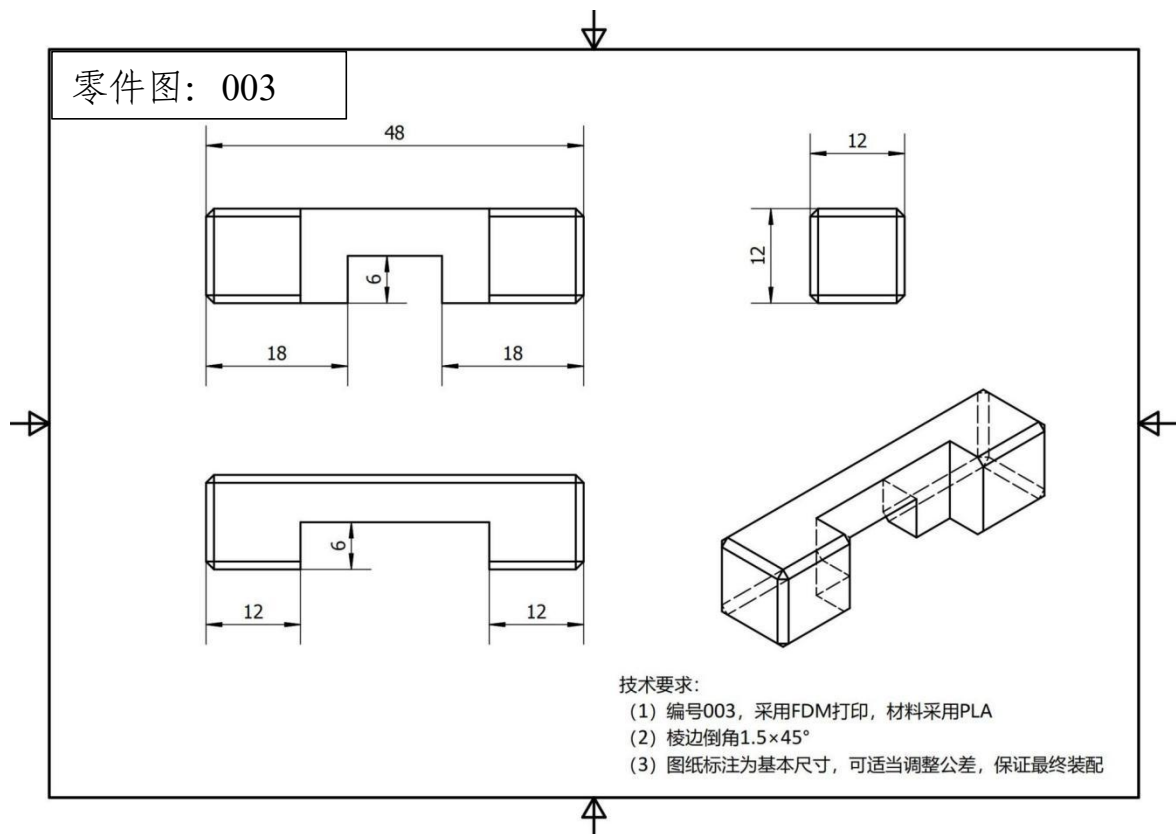

零件图 003	Parts Drawing 003
<p>技术要求：</p> <p>(1) 编号 003，采用 FDM 打印，材料采用 PLA</p> <p>(2) 棱边倒角 <math>1.5 \times 45^\circ</math></p> <p>(3) 图纸标注为基本尺寸，可适当调整公差，保证最终装配</p>	<p>Technical Requirements:</p> <p>(1) No. 003, use FDM print and PLA material</p> <p>(2) Seamed edge chamfer: <math>1.5 \times 45^\circ</math></p> <p>(3) The drawing is marked as basic size, tolerance can be adjusted to ensure final assembly</p>

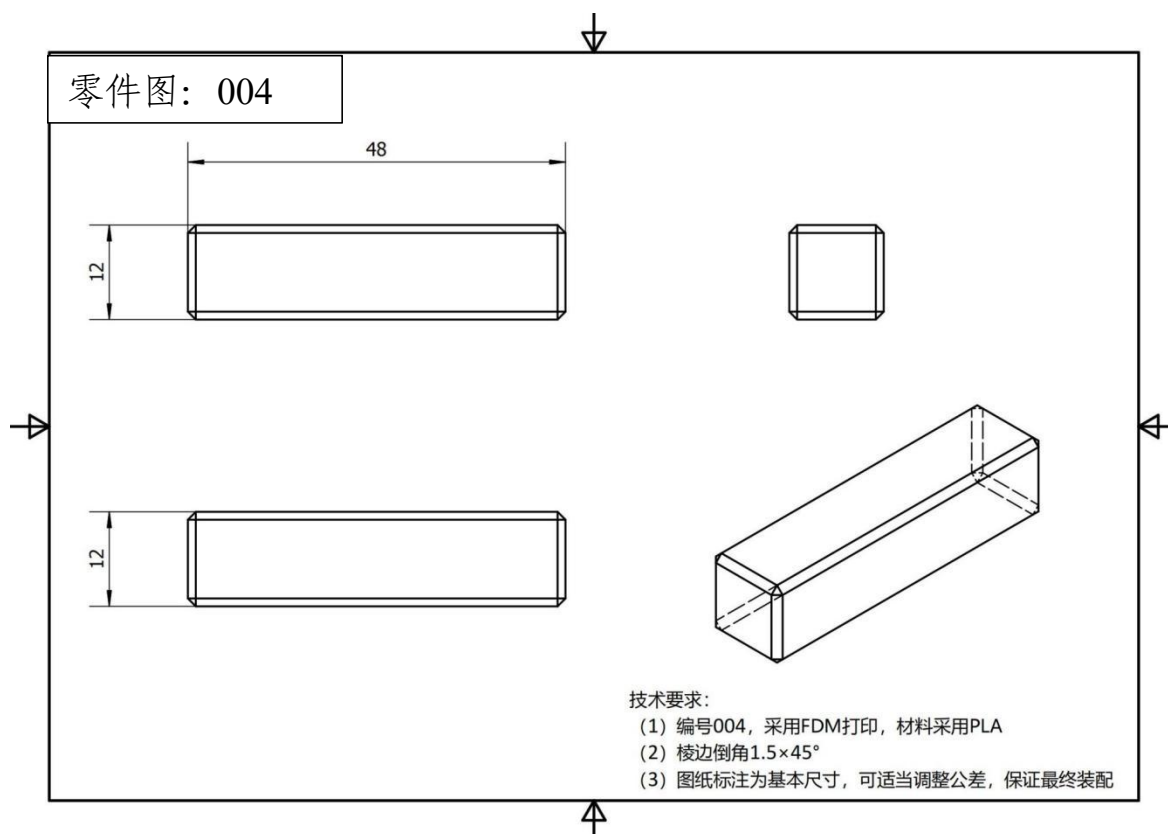

零件图 004	Parts Drawing 004
<p>技术要求:</p> <ol style="list-style-type: none"> <li>(1) 编号 004, 采用 FDM 打印, 材料采用 PLA</li> <li>(2) 棱边倒角 <math>1.5 \times 45^\circ</math></li> <li>(3) 图纸标注为基本尺寸, 可适当调整公差, 保证最终装配</li> </ol>	<p>Technical Requirements:</p> <ol style="list-style-type: none"> <li>(1) No. 004, use FDM print and PLA material</li> <li>(2) Seamed edge chamfer: <math>1.5 \times 45^\circ</math></li> <li>(3) The drawing is marked as basic size, tolerance can be adjusted to ensure final assembly</li> </ol>



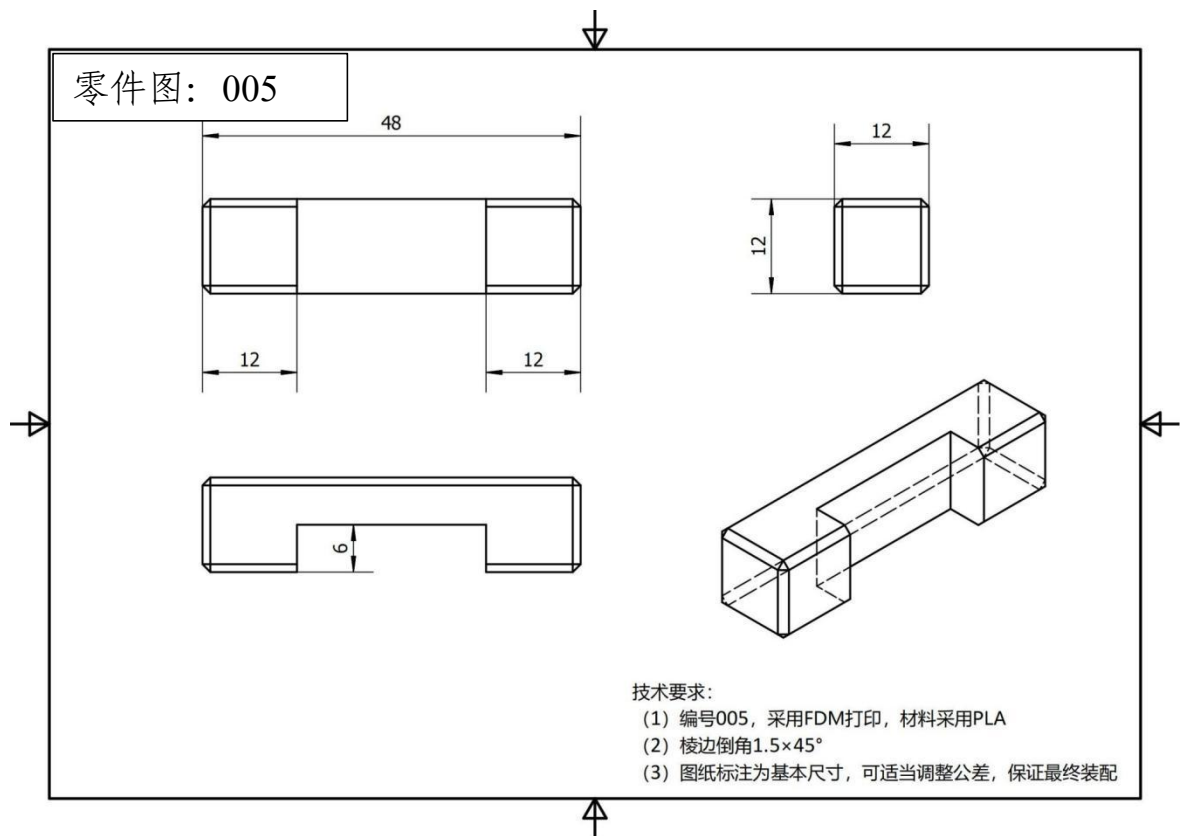

零件图 005	Parts Drawing 005
<p>技术要求:</p> <ol style="list-style-type: none"> <li>(1) 编号 005, 采用 FDM 打印, 材料采用 PLA</li> <li>(2) 棱边倒角 <math>1.5 \times 45^\circ</math></li> <li>(3) 图纸标注为基本尺寸, 可适当调整公差, 保证最终装配</li> </ol>	<p>Technical Requirements:</p> <ol style="list-style-type: none"> <li>(1) No. 005, use FDM print and PLA material</li> <li>(2) Seamed edge chamfer: <math>1.5 \times 45^\circ</math></li> <li>(3) The drawing is marked as basic size, tolerance can be adjusted to ensure final assembly</li> </ol>

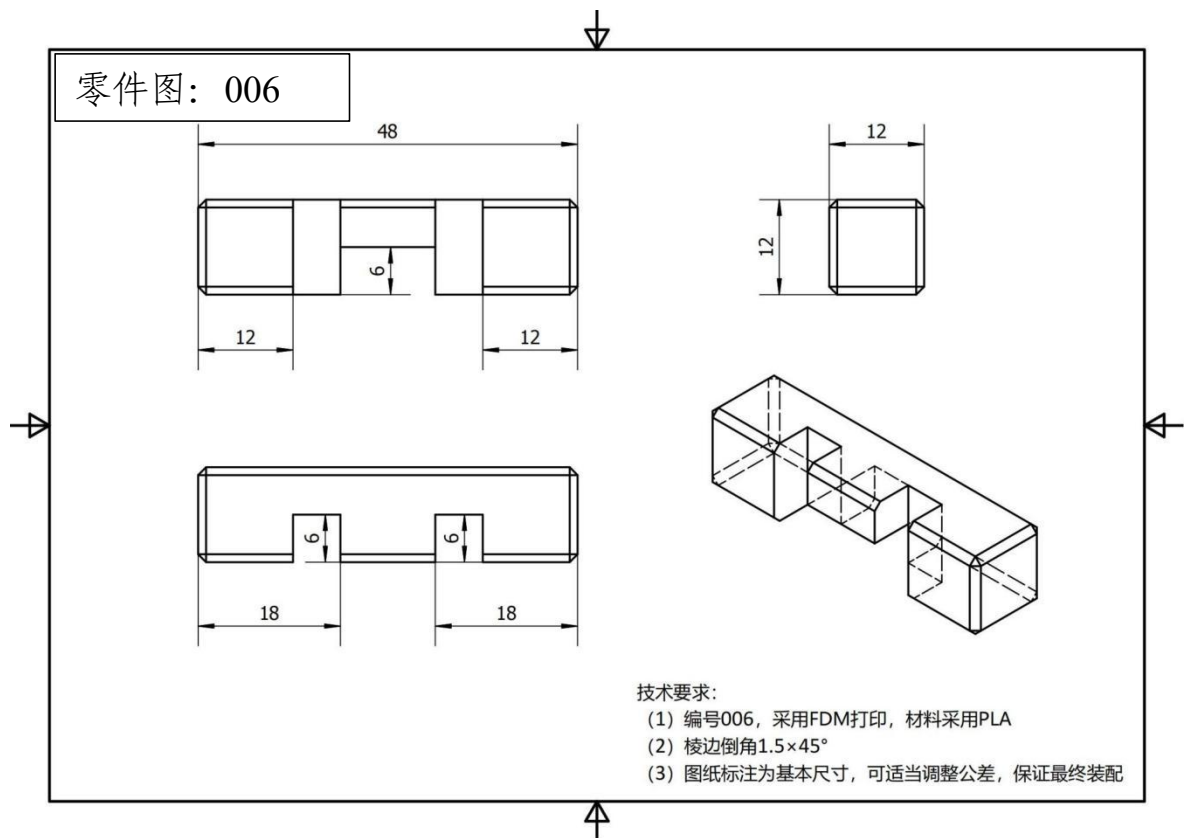

零件图 006	Parts Drawing 006
技术要求： (1) 编号 006，采用 FDM 打印，材料采用 PLA (2) 棱边倒角 $1.5 \times 45^\circ$ (3) 图纸标注为基本尺寸，可适当调整公差， 保证最终装配	Technical Requirements: (1) No. 006, use FDM print and PLA material (2) Seamed edge chamfer: $1.5 \times 45^\circ$ (3) The drawing is marked as basic size, tolerance can be adjusted to ensure final assembly

**Competition of Additive Manufacturing Technology -- Test Project for the B Module of Innovative and Creative Design**

**Competition of Additive Manufacturing  
Technology -- Test Project for the B  
Module of Innovative and Creative Design**

## I. Name of Design

1. Name of design: A manual cooling fan
2. Design time: Each team must formulate two design plans, in accordance with the test project, one of which should be selected to complete all competition contents on-site. Foreign competitors should complete at least one set of design documents. Meanwhile, teams should prepare an English PowerPoint file that records the design process, which should be submitted, as a marking basis for the online competition, together with the documents required in the tasks, such as digital model files, to the email address (guosaichengban-jwc@tjtc.edu.cn) designated for the Competition of Additive Manufacturing Technology before the Competition ends.

## II. Description of Phased Tasks

It is getting hotter, as summer draws near. Plus the need of pandemic prevention and control, cooling and ventilation will be normalized. Generally, there are many cooling devices, such as air-conditioners and electric fans. Yet, such devices are driven electrically. Small fans with a small battery are also available, but they have a limited battery life and are inconvenient to carry as they are heavy, and are not eco-friendly. As a result, it is of practical value to design a cooling fan that is not electrically driven, and that is small, portable, and available anytime.

In response to this demand, please design a manual cooling fan with an aesthetic appearance. The user will manually (rather than electrically) start the gears that will drive the blades to have a cooling effect. A fan without gears is shown in the schematic diagram.



### 1. Known conditions and design requirements

There is a known candle flame to test the power of the fan. Competitors should design a manual cooling fan. The fan, when manually operated 100mm away, should blow out the flame. The structure of fan blades of the manual cooling fan must be designed. All parts should be printed. No parts, such as fasteners, will be provided on-site. The fan blades of the finalized fan, when manually and continuously driven, should be able to rotate in one direction for longer than one minute. The gear and power source of the fan should be designed competitors independently. The maximum dimension should be smaller than 120mm x 120mm x 40mm. In addition, the fan should be portable, small, and light with an aesthetic appearance.

### 2. Competition tasks, requirements, the key points of marking, and deliverables

The structure of files to be delivered for this module is shown in the figure below. The confirmation forms of the equipment and tools of the B, C, D and E modules should be filled in at the beginning of the Competition. Four tasks are covered in the Competition. Materials completed for each task should be stored in a separate folder. Finally, the four folders and the PowerPoint file recording the working process should be stored in an

encrypted folder designated by the Competition and submitted together as required. For files in the folders, see the requirements of the specific tasks.



### Task I Schematic Design (25 Points)

Competitors should design a manual cooling fan based on the known conditions, complete the 2D engineering drawing of all the internal and external parts of the fan (including size and form and location tolerance), and generate 2D drawings of parts and a 2D assembly diagram. Specific requirements are as follows:

1. The view expression of the 2D drawings of parts and the 2D assembly diagram should be reasonable;
2. Technical requirements are specified in a clear and specific manner in the 2D drawings of parts and the 2D assembly diagram;
3. The 2D drawings should cover all parts;
4. For all parts, size and the main form and location tolerance should be specified;
5. The size and matching relationship of the main parts should be specified in the 2D assembly diagram;
6. The 2D drawings of parts and the 2D assembly diagram should be consistent with the subsequent task requirements.

Deliverables: The folder "21-FanSketch" contains a source document of the 2D drawings of parts and a source document of the 2D assembly diagram. Specifically, the drawings of parts are named in the format "FanSketch-part-X", in which "X" means the serial number of a part. Thus, such drawings will be named in numerical order. The assembly diagram is named "FanSketch-assembly". The file format of the drawings of parts and the assembly diagram should be "dwg" or "dxf".

Marks and indicators are allocated below:

Indicators	PowerPoint file	View expression and technical	Size specified in the	Form and location tolerance	Size specified in the	The matching relationship

		requirements	drawings of parts	specified in the drawings of parts	assembly diagram	specified in the assembly diagram
Marks	2	6	7	5	3	2

Note: If the drawings of parts and the assembly diagram are completely inconsistent with the content completed in the subsequent tasks, no points will be given to this task.

### Task II Design of the Internal Movement Mechanism of the Product (25 Points)

Competitors should design the internal movement mechanism of the manual cooling fan with the pre-installed software in the computer, based on the known conditions. Specific requirements are as follows:

1. The gear and power source of the fan should be designed by competitors independently. The fan blades should be able to rotate in one direction for longer than one minute;
2. The structure of fan blades of the manual cooling fan must be designed;
3. The concept of integrated structural design should be reflected, and the operation should be smooth;
4. The concept of lightweight design should be reflected, and the operation should be convenient;
5. The connection among parts should be reasonable.

Deliverables: The folder "22-FanMotion" contains a source document of innovative 3D design and a file in an intermediate exchange format. Specifically, the assembly file of the source document is named "FanMotion". The relevant part files are also stored in this folder. There are no naming restrictions, but the assembly file should be ensured that it can be opened. The file in an intermediate exchange format is an "stp" file, named "FanMotion-stp". The whole assembly is stored as a single stp file.

Marks and indicators are allocated below:

Indicators	PowerPoint file	Design of the power source	Structure of fan blades	Gear structure	Integrated structural design	Lightweight design	Reasonable connection among parts
Marks	2	3	3	5	5	5	2

### Task III Design of Product Appearance (25 Points)

Please design the appearance of the manual cooling fan, in accordance with the digital model exported in "Task II". Specific requirements are as follows:

1. The appearance should be aesthetic, subject to ergonomic principles, and convenient to use;
2. It should be convenient to assemble and remove the shell and gears of the fan;

3. It should be convenient to assemble the internal movement mechanism that has been completed in “Task II”;
4. The appearance should not affect the power output of the power source;
5. The appearance should conform to the 3D printing processes.

Deliverables: The folder "23-Fan" contains a source document of innovative 3D design and a file in an intermediate exchange format (including all parts, such as those of internal movement mechanism). Specifically, the assembly file of the source document is named "Fan". The relevant part files are also stored in this folder. There are no naming restrictions, but the assembly file should be ensured that it can be opened. The file in an intermediate exchange format is an "stp" file, named "Fan-stp". The whole assembly is stored as a single stp file.

Marks and indicators are allocated below:

Indicators	PowerPoint file	The appearance should be aesthetic and subject to ergonomic principles.	Assembly and removal should be convenient.	“Power output” should not be affected.	It should be convenient to assemble the internal movement mechanism.	3D printing processes should be followed.
Marks	2	6	4	4	4	5

#### **Task IV Design of the Movement Simulation of the Product (25 Points)**

The movement simulation of the product should be designed, based on the digital models completed in “Task II” and “Task III”. Specific requirements are as follows:

1. The parts of the product models are completely assembled;
2. The assembly relationship is correct;
3. The constraint relationship is correct;
4. An animation of cyclic movement should be produced;
5. The animation should be output as .AVI.

Deliverables: The folder "24-FanSim" contains a source document of product assembly, including movement simulation, as well as an animation of movement simulation. The source document of product assembly is named "FanSim". The relevant part files are also stored in this folder. There are no naming restrictions, but the assembly file should be ensured that it can be opened. The animation of movement simulation is in the "avi" format and named "FanSim.avi".

Marks and indicators are allocated below:

Indicators	PowerPoint file	The design process is clearly expressed.	The assembly relationship is clearly expressed.	Performance characteristics are demonstrated.	The output format of the animation
------------	-----------------	--	---	---	------------------------------------

Marks	2	8	8	5	2
-------	---	---	---	---	---



**Competition of Additive Manufacturing Technology -- Test Project  
for the C Module of 3D Printing Processes**

**Competition of Additive Manufacturing  
Technology -- Test Project for the C  
Module of 3D Printing Processes**

### **Task: 3D Printing and Post-processing of the Product**

The product should be 3D printed, formed, and processed, based on the 3D printing and forming equipment, the supporting equipment operating software, and consumables provided onsite, as well as the digital models completed, such as that of the manual cooling fan. Competitors should input the data models to the 3D printing and forming equipment, select and set processing parameters, and conduct 3D printing, forming, and processing as required. Post-processing of 3D printed pieces: Polishing, connection, and repair. Supporting materials should be taken off, and the surface of all parts of the product should be polished. The product should be assembled. All parts should be printed. No other accessories should be used. Parts should not be bound to each other.

Deliverables: The printed and post-processed product should be put in the file pocket of the Competition and sealed and kept by judges.

Marks and indicators are allocated below:

Indicators	Parts are completely printed.	Supporting materials are taken off.	Surface roughness	Integrated structural production	Overall assembly	Blow-out test
Marks	25	10	10	10	20	25

**Competition of Additive Manufacturing Technology -- Test Project  
for the D Module of Work Demonstration**

**Competition of Additive Manufacturing  
Technology -- Test Project for the D  
Module of Work Demonstration**

### **Task: Work Demonstration**

As required in the Test Project, the work should be demonstrated, after the three modules, such as the manual cooling fan, are completed.

The on-site record sheets should be filled in. This module should be completed under the supervision of both onsite and online judges and then reviewed and confirmed by the jury president. The demonstration effect and the compliance of the work should be completed within the prescribed time. Successful attempts, the experimental distance, and continuous movement should be recorded.

Indicators	Compliance of the work	Demonstration effect	Safety	Reliability	Demonstration time	Demonstration times
Marks	40%	30%	10%	10%	5%	5%

**Competition of Additive Manufacturing Technology -- Test Project  
for the E Module of Professional Quality**

**Competition of Additive Manufacturing  
Technology -- Test Project for the E  
Module of Professional Quality**

### **Task: Professional Quality**

The following aspects of teams during all phases of the competition should be mainly assessed:

1. Standardization of equipment operation;
2. Use of tools and measuring instruments;
3. Safe and ethical production onsite;
4. The planning and logic for completing tasks, and response to problems.

Marks and indicators are allocated below:

Indicators	Standardization of equipment operation	Correct use of tools and measuring instruments	Safe and ethical production	Miscellaneous
Marks	40	20	20	20

Assessment criteria: Deductions of the module should be jointly proposed by onsite and online judges and then reviewed and confirmed by the jury president.

Zero point should be granted to the module of professional quality, if competitors obviously violate professional ethics, competition discipline, or safety operating procedures, or damage equipment, tools, or measuring instruments, and leading to a serious consequence. The handling decision should be jointly proposed by onsite and online judges and agreed with by the jury president.